

Aufbausätze

Montagebeispiel

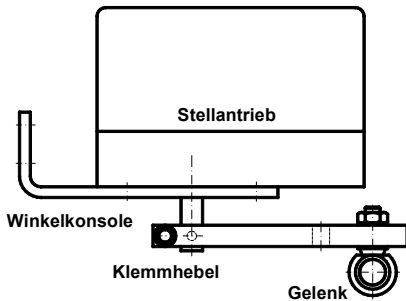

Klemmhebel KH 20

Mat.: Stahl, verzinkt

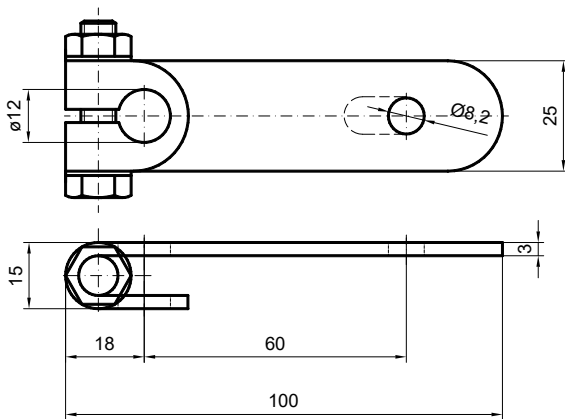

Klemmhebel KH 40-300

Mat.: Alu oder Stahl, verzinkt

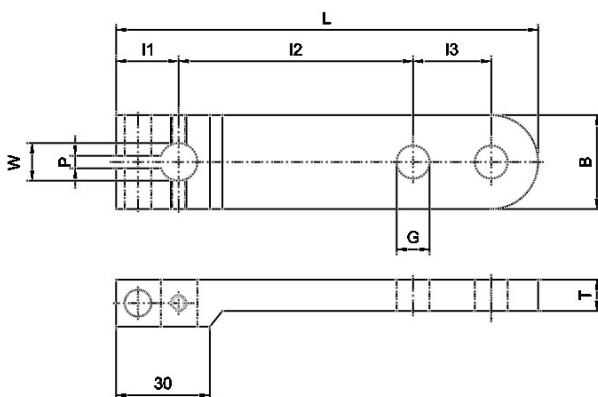

B.-Nr.	W	L	l1	l2	l3	G	B	P	T
32050	12	135	20	75	25	10,5	30	4	10
32055	14	135	20	75	25	10,5	30	5	10
32060	20	196	26	100	50	16,5	40	6	14
32065	25	196	26	100	50	16,5	40	8	14

Gelenk GK

Mat.: Stahl, verzinkt

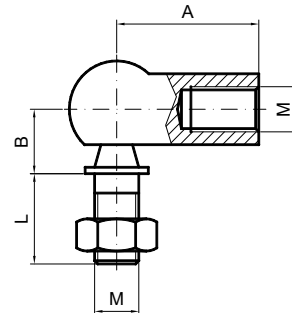

B.-Nr.	M	A	B	L
32100	10	35	16	20
32110	16	45	20	28

Gestänge GS, Federgestänge FGS

Mat.: Stahl, verzinkt

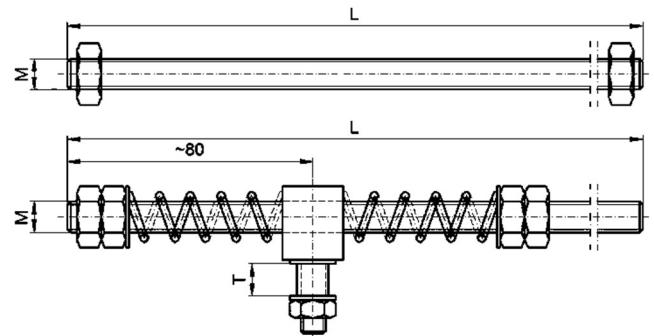

B.-Nr. GS	B.-Nr. FGS	M	L	T
32150	32180	M10	500	10
32155	32181	M10	1000	10
32170	32185	M16	500	14
32175	32186	M16	1000	14

Winkelkonsole WKL

Mat.: Edelstahl, 1.4301

