

Lift drive HAK

Technical data

Force	max. 2500N
Displacement	50 / 100 / 150 / 300 / 500 / 750 / 1000mm
Actuating time	0,1 up to 20mm/s, load-independent at AC
Voltage	230V AC, 50 / 60 Hz Option 24/115VAC, 400VDS, 12/24VDC
Amb. temperature	-15°C to +60°C
Protection	IP 65

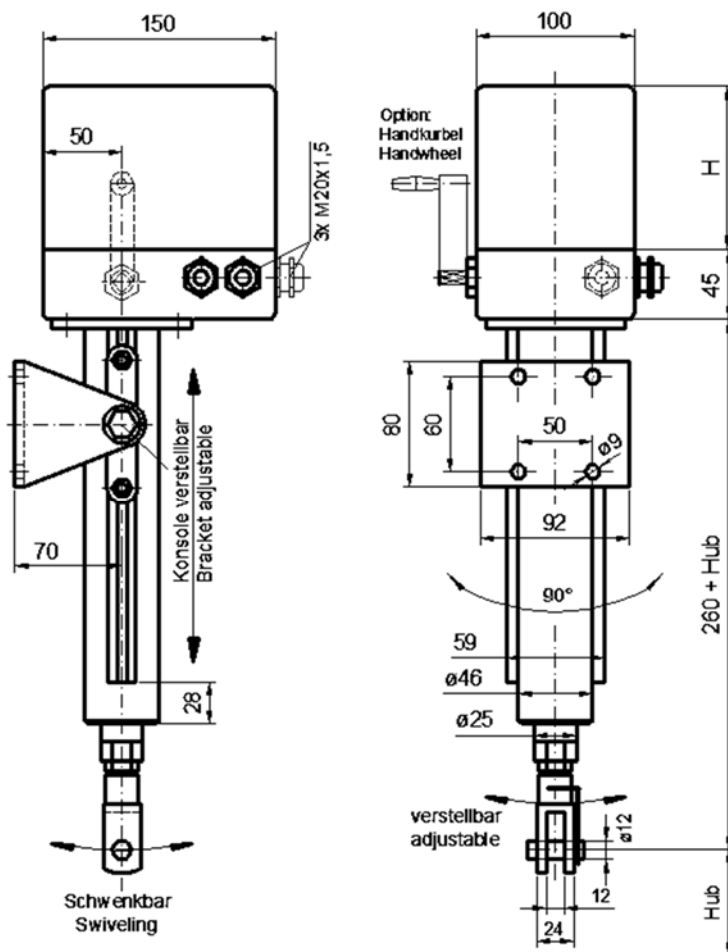

General data

Compact design built to industrial standard

Mounting bracket adjustable

Mounting pipe adjustable

Coupling adjustable

To fit any fitting position

Short-circuit proof synchronous motor

Robust and maintenance free

Control cam fine adjustment

Centralized power transmission

Protected spindle Tr 18x4

Cover-height H98 -178 acc. options

Numerous options:

Additional switches, Potentiometer

Position indicator or positioner

Hand wheel, gear disengagement ...